



**Cambridge International Examinations**  
Cambridge International General Certificate of Secondary Education

CANDIDATE NAME

CENTRE NUMBER 

|  |  |  |  |  |
|--|--|--|--|--|
|  |  |  |  |  |
|--|--|--|--|--|

CANDIDATE NUMBER 

|  |  |  |  |
|--|--|--|--|
|  |  |  |  |
|--|--|--|--|

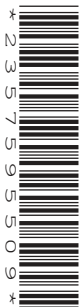

**DESIGN AND TECHNOLOGY** **0445/31**  
Paper 3 Resistant Materials **October/November 2014**  
**1 hour**

Candidates answer on the Question Paper.

No Additional Materials are required.

**To be taken together with Paper 1 in one session of 2 hours 15 minutes.**

**READ THESE INSTRUCTIONS FIRST**

Write your Centre number, candidate number and name on all the work you hand in.

Write in blue or black pen.

You may use an HB pencil for any diagrams, graphs or rough working.

Do not use staples, paper clips, glue or correction fluid.

**DO NOT WRITE IN ANY BARCODES.**

**Section A**

Answer **all** questions in this section.

**Section B**

Answer **one** question in this section.

You may use a calculator.

The total of the marks for this paper is 50.

The number of marks is given in brackets [ ] at the end of each question or part question.

| For Examiner's Use |  |
|--------------------|--|
| <b>Section A</b>   |  |
| <b>Section B</b>   |  |
| <b>Total</b>       |  |

This document consists of **17** printed pages and **3** blank pages.

**Section A**

Answer **all** questions in this section.

1 Fig. 1 shows a chair made from plastic and metal.

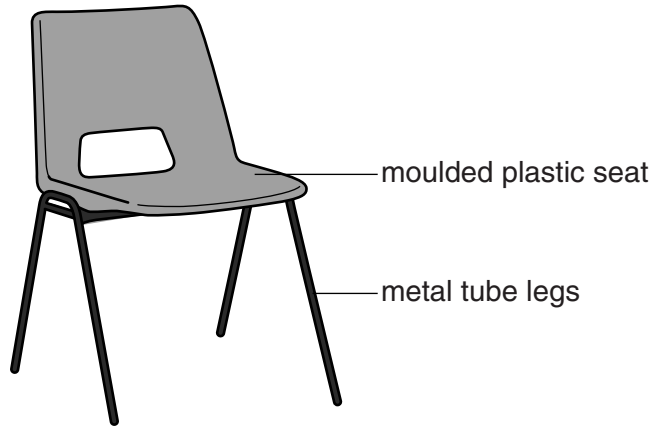

**Fig. 1**

(a) Name a suitable metal for the legs.

.....[1]

(b) Name a suitable plastic for the seat.

.....[1]

(c) The metal legs have an applied finish on them. Name a suitable finish for the metal legs.

.....[1]

(d) Give **one** reason for applying a finish to the metal legs.

.....[1]

2 Complete the table below by naming each tool and giving a specific use.

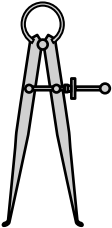
| Tool  | Name | Specific use |
|---|------|--------------|
|  |      |              |
|  |      |              |

[4]

3 Fig. 2 shows a cordless electric drill and a bench pillar drill.

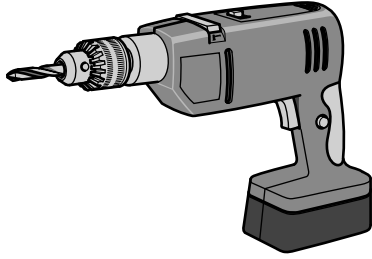

cordless electric drill

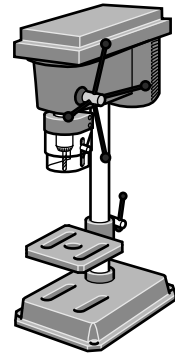

bench pillar drill

Fig. 2

Give **one** benefit of drilling holes using:

(a) a cordless electric drill

.....[1]

(b) a bench pillar drill.

.....[1]

4 Fig. 3 shows a piece of wood being sawn.

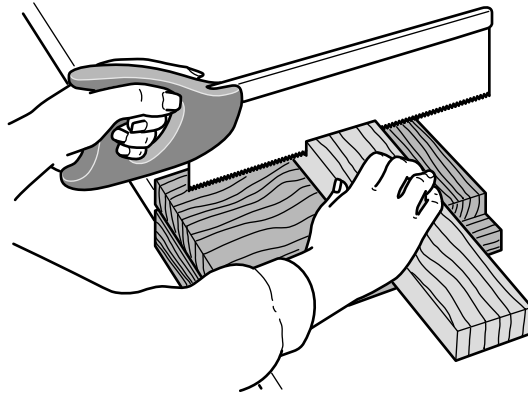

Fig. 3

(a) Give the specific name of the saw being used.

.....[1]

(b) Name the equipment that the wood being sawn is held against.

.....[1]

5 Fig. 4 shows two tools being used to mark the centre of a rod.

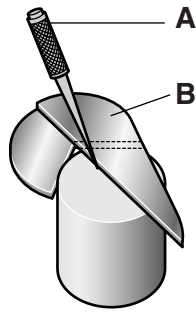

Fig. 4

Name tools **A** and **B** shown in Fig. 4.

**A** .....

**B** ..... [2]

6 Fig. 5 shows a split pattern used to make a hacksaw handle.

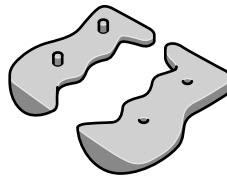

Fig. 5

Name the process that uses a split pattern to make the hacksaw handle.

..... [1]

- 7 Fig. 6 shows a triangular shape made from acrylic. Each side of the triangular shape is 60 mm long.

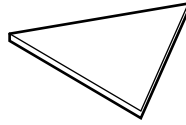

Fig. 6

Complete the drawing below by showing how **three** shapes could be marked out on the acrylic sheet with the minimum of waste.



[2]

- 8 Fig. 7 shows part of a woodworker's bench.

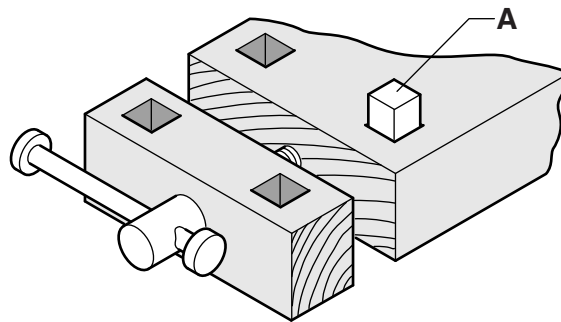

Fig. 7

- (a) Name the piece of equipment labelled **A** in Fig. 7.

.....[1]

- (b) Give **one** specific use for this piece of equipment.

.....[1]

9 Fig. 8 shows two pieces of 15 mm thick hardwood.

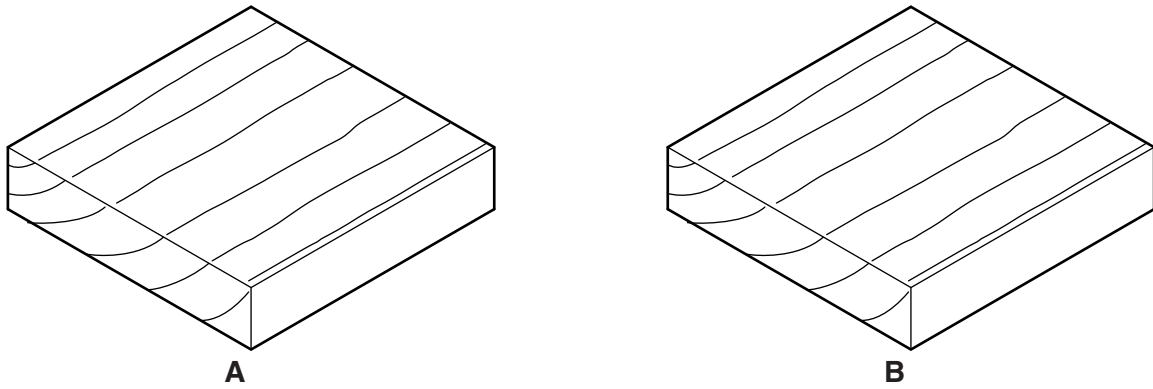

Fig. 8

(a) Draw on **A** in Fig. 8 to show a groove. [2]

(b) Draw on **B** in Fig. 8 to show a through housing joint. [2]

10 Fig. 9 shows a product that has been blister packaged.

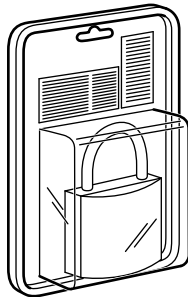

Fig. 9

(a) Name a suitable plastic for the packaging.  
 .....[1]

(b) Give **one** benefit of blister packaging.  
 .....[1]

**Section B**

Answer **one** question from this section.

- 11 Fig. 10 shows an incomplete design for a coat rack that fits over the top of a door. The coat rack is made from 1 mm thick metal strip and will be made in a school workshop.

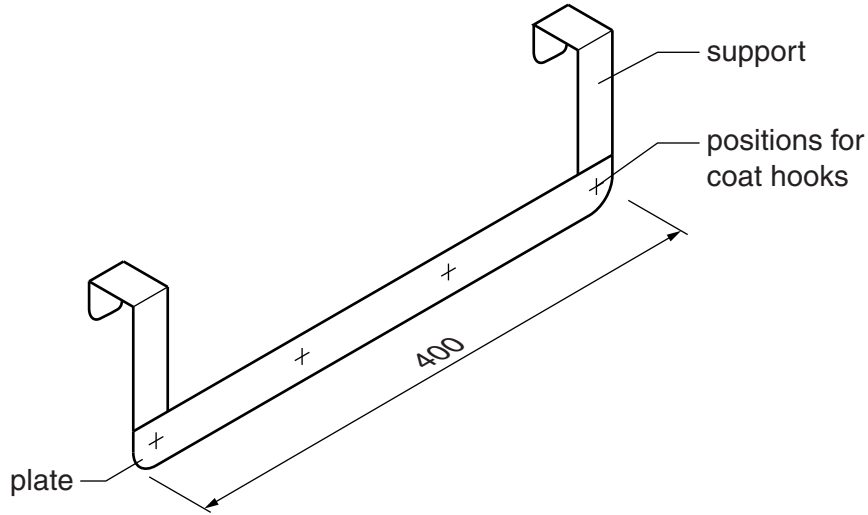

**Fig. 10**

- (a) State **two** items of research the designer would consider in the design of the coat rack.

1 .....

2 .....[2]

- (b) Fig. 11 shows one support marked out, ready to be bent to shape.

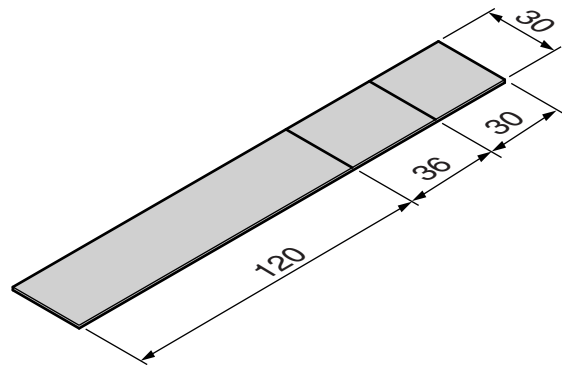

**Fig. 11**

- (i) Name **two** marking out tools used to mark out the support.

1 .....

2 .....[2]

- (ii) Give **one** reason why engineers blue is sometimes used when marking out.

.....[1]

(c) Use sketches and notes to show how you would bend the metal strip to make the support.

[3]

(d) (i) Explain why it could be necessary to anneal metal.

.....  
.....  
.....[2]

(ii) Describe how you would anneal brass.

.....  
.....[3]

(e) The coat rack in Fig. 10 could be made from brass.

Name an applied finish for the coat rack when made from brass.

.....[1]

(f) Describe how you would prepare brass from a sawn finish to a polished surface.

.....  
.....  
.....  
.....[3]



**(g) (i)** The positions for four coat hooks are shown in Fig. 10.

Use sketches and notes to show a design for a coat hook that could be joined to the plate. Include details of sizes and materials used.

[3]

**(ii)** Describe in detail the processes involved when joining the coat hook designed in **(g)(i)** permanently to the plate. The use of adhesive is not allowed.

[5]

12 Fig. 12 shows an incomplete design for a child’s sit-on toy. The wheels have been removed. The sit-on toy is 700 high × 500 wide and is made from 18 mm thick plywood.

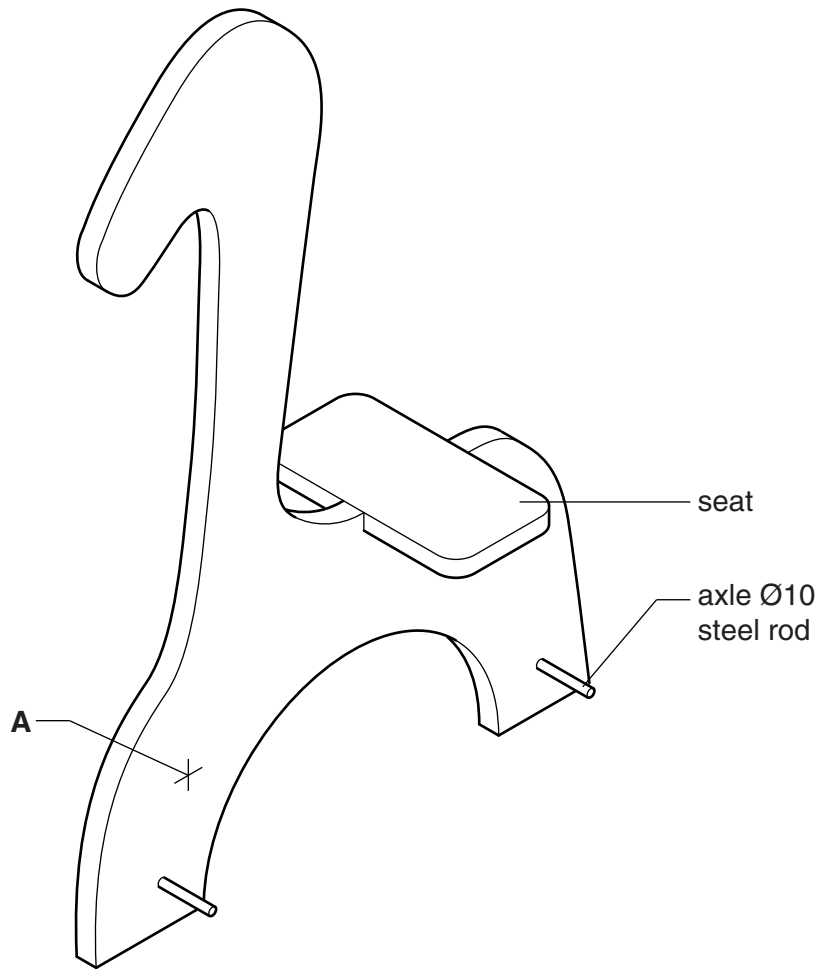

Fig. 12

(a) Give **two** advantages of using plywood rather than solid wood for the sit-on toy.

1 .....

2 .....[2]

(b) The shape of the sit-on toy will be cut out from a large sheet of plywood.

(i) Name a portable power tool that could be used to cut out the shape.

.....[1]

(ii) State **two** safety precautions you would take when using portable power tools.

1 .....

2 .....[2]

(c) Fig. 13 shows details of the slot into which the seat will fit.

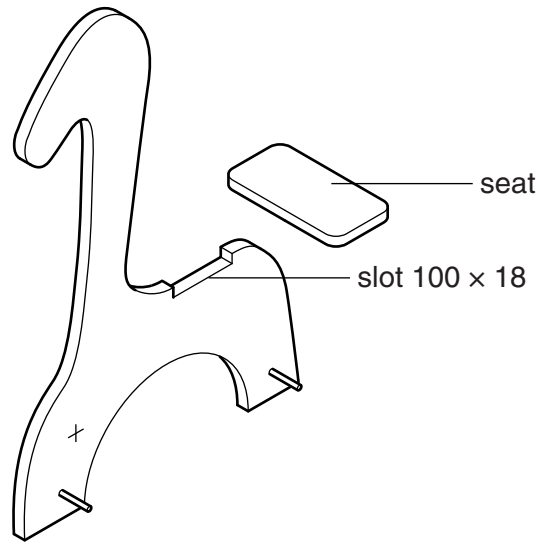

**Fig. 13**

- (i) Use sketches and notes to show how the slot could be cut out by hand. Name **all** the tools and equipment used.

[4]

- (ii) Use sketches and notes to show how the fixing of the seat could be strengthened. Include details of materials, sizes and fittings used.

[4]

(d) A foot rest is needed for the sit-on toy. The footrest is to be fitted at **A** in Fig. 12.

Use sketches and notes to design a foot rest that could be adjusted and fixed at **three** different heights. Include details of materials, sizes and fittings.

[5]

(e) Explain how the designer has considered anthropometric data in the design of the sit-on toy.

.....

.....

.....

.....[2]

- (f) Fig. 14 shows one of the wheels for the sit-on toy. The wheels are made from a plastic.

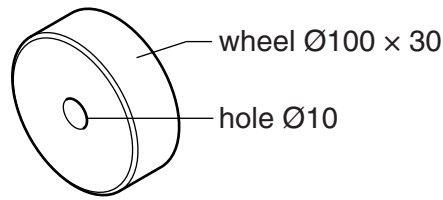

**Fig. 14**

- (i) Name a method of manufacture for the wheel.

.....[1]

- (ii) Use sketches and notes to show how the front wheels could be fitted to the sit-on toy. The wheels must be allowed to turn freely and must be safe in use. Include details of materials, sizes and fittings used.

[4]

- 13 Fig. 15 shows a DVD stand made mainly from hardwood.  
The bottom of the DVD stand can rotate on the base as shown by the arrows in Fig. 15.

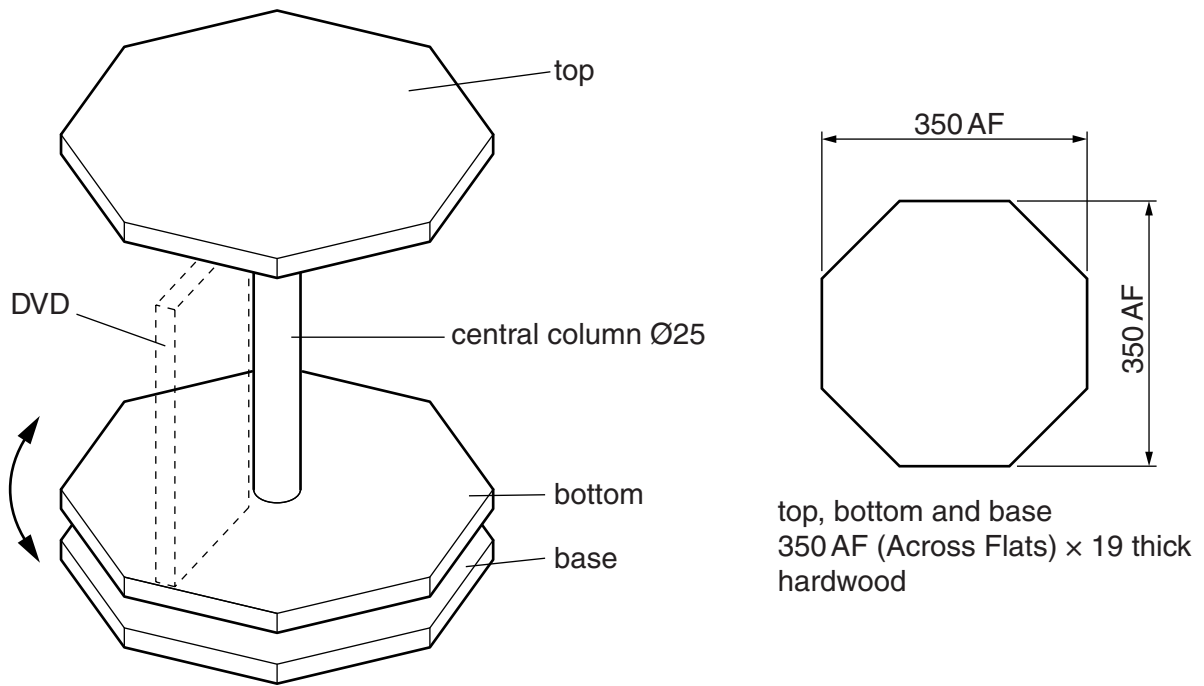
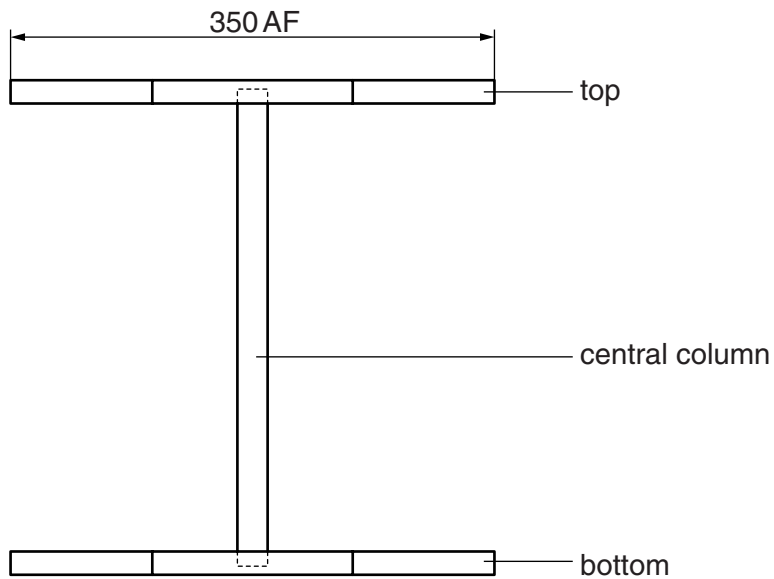

**Fig. 15**

- (a) Use sketches and notes to show how the hardwood top could be made in a school workshop. Include details of marking out.

- (b) The top and bottom will be joined by the central column.

Complete the drawing below to show how the top and bottom could be clamped together while the adhesive sets.



[3]

- (c) Use sketches and notes to show how the assembled top and bottom of the DVD stand could be made to rotate on the base. The base must remain level when rotated. Include details of materials and fittings used.

[4]

(d) Fig. 16 shows details of one DVD and the arrangement for storing 12 DVDs.

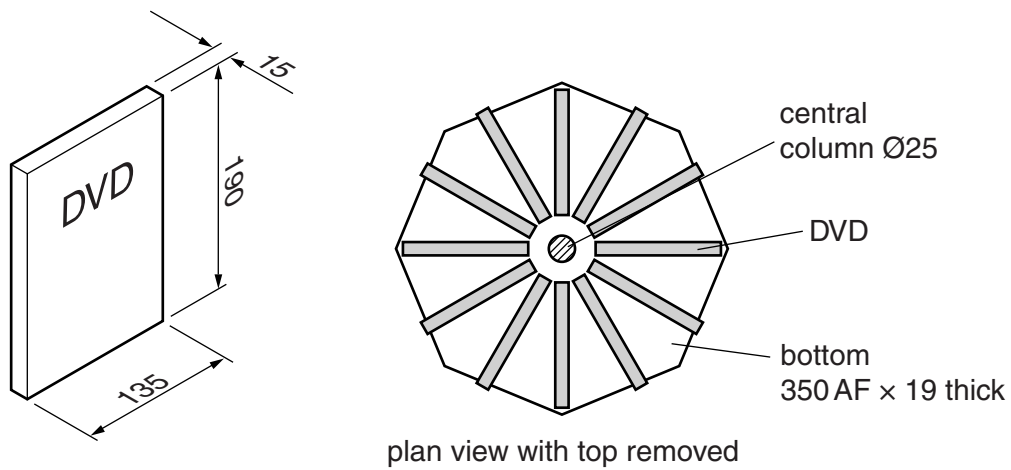

**Fig. 16**

Use sketches and notes to show:

- how each DVD could be located in its own position;
- details of materials, constructions and fittings used.



- (e) (i) Name a suitable finish, other than varnish, for the DVD stand.  
.....[1]
- (ii) Describe how the hardwood could be prepared to take your chosen finish.  
.....  
.....  
.....[2]
- (f) Describe when the following could be used in the manufacture of the DVD stand:  
template .....  
jig .....[2]
- (g) Explain why the hardwood used to make the DVD stand would need to be seasoned.  
.....  
.....  
.....[2]





**BLANK PAGE**

---

Permission to reproduce items where third-party owned material protected by copyright is included has been sought and cleared where possible. Every reasonable effort has been made by the publisher (UCLES) to trace copyright holders, but if any items requiring clearance have unwittingly been included, the publisher will be pleased to make amends at the earliest possible opportunity.

Cambridge International Examinations is part of the Cambridge Assessment Group. Cambridge Assessment is the brand name of University of Cambridge Local Examinations Syndicate (UCLES), which is itself a department of the University of Cambridge.